



M³ INSPIRATION

MODERN. MAGNETIC. MODULAR.



In-Ground Channel Light



IK10

Lamps can bear more than
2000lbs

Integrated high-power

LED

IP67

IN-GROUND MODULAR CHANNEL LIGHT

This linear and waterproof LED light can be mounted in a floor or wall. Due to its small size (1.4-1.6" wide and 2.6" tall) it can adapt to a variety of spaces. Quick and easy to install, this series has optional accessories that create a variety of shapes to allow the versatility and creative freedom designers need.

Its lightweight and durable body is made from high-strength casted aluminum. The lamp is sealed by reinforced glass, a rubber ring, and silicone to prevent water damage. Hardened glass is used to resist extreme temperature, impact, friction, and pressure. Light transmittance is as high as 92% and the product can withstand over 2,000 lbs of weight .

www.SARINEnergy.com

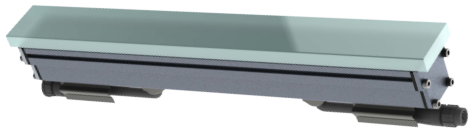

1' Titan Module
7.5W, 375lm, 11.8" Length

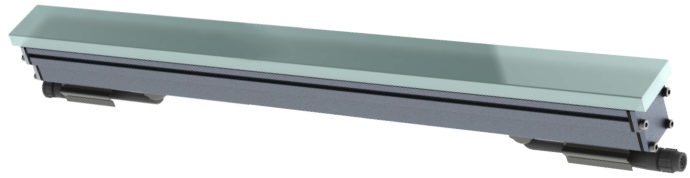

2' Titan Module
15W, 750lm, 22.8" Length

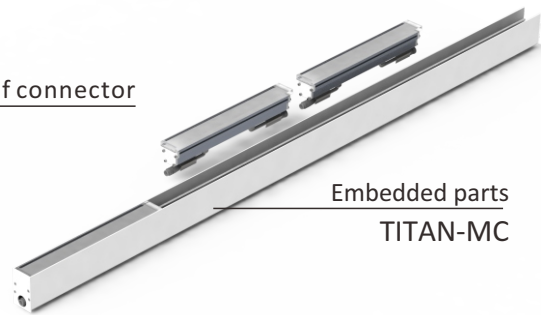
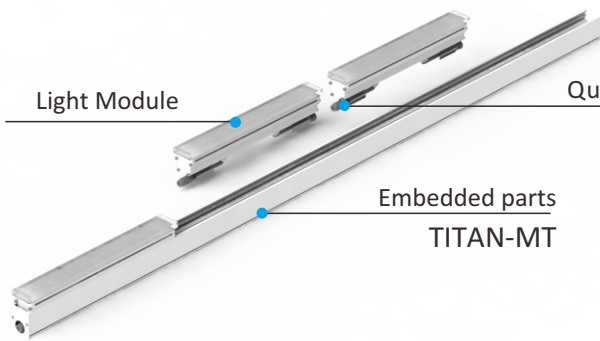

Two kinds of embedded part installation renderings

TITAN-MT

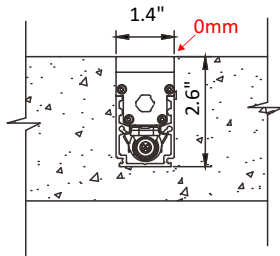

TITAN-MC

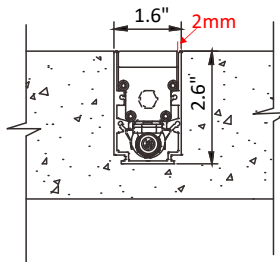



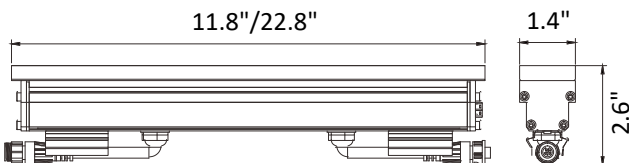









Quick waterproof connector



LED

Product List

- LED chip: **PHILIPS**
- Driver brand:  certification
- CRI >80
- Life 50,000h
- Color temperature:
Cool white 6500K
Neutral white 4000K
Warm white 3000K
Red, Blue, or Green

Item No.	Power	Size	Image
SES-TITAN-7.5	7.5W	1.4" x 2.3" x 11.8"	
SES-TITAN-15	15W	1.4" x 2.3" x 22.8"	
SES-TITAN-MT	Light Base (Trimless)	1.4" x 1.7" x 11.8" / 22.8" / 44.6" / 94.5" / 118.1"	
SES-TITAN-MC	Light Base (Trim)	1.6" x 2.6" x 11.8" / 22.8" / 44.6" / 94.5" / 118.1"	
 Drivers	100W / 150W / 200W		
SES-TITAN-MT-End-Cap			
SES-TITAN-MC-End-Cap			
SES-TITAN-Cable		39.4" / 78.7"	
SES-TITAN-Bolt-S			
SES-TITAN-90°-Connector			
SES-TITAN-180°-Connector			
SES-TITAN-Driver-Box			





Installation

1. EMBEDDED IN EXISTING MASONRY

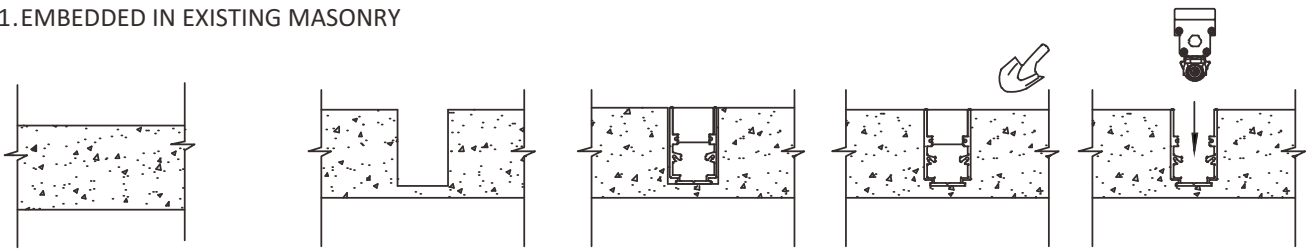

2. EMBEDDED IN FRESH CONCRETE

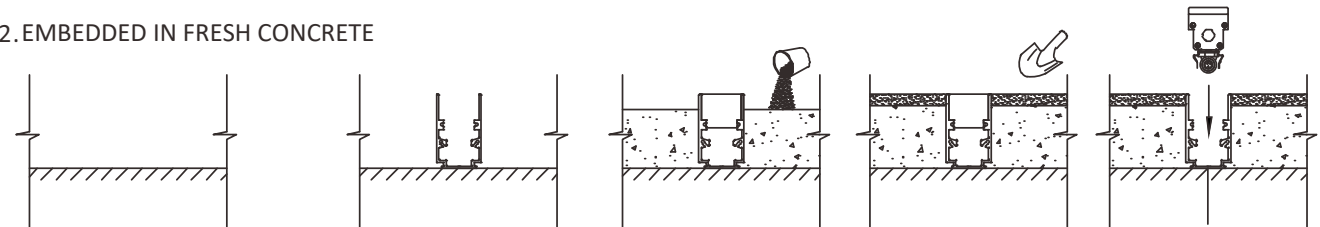

3. SURFACE MOUNTED ON THE GROUND OR WALL

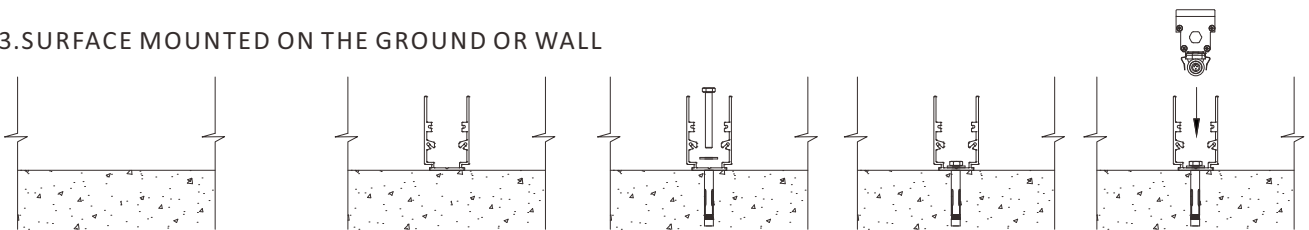

WARNING

Do the construction without groundwater infiltration, the light cannot function if it gets wet.



Embedded parts installation
Optional accessories package

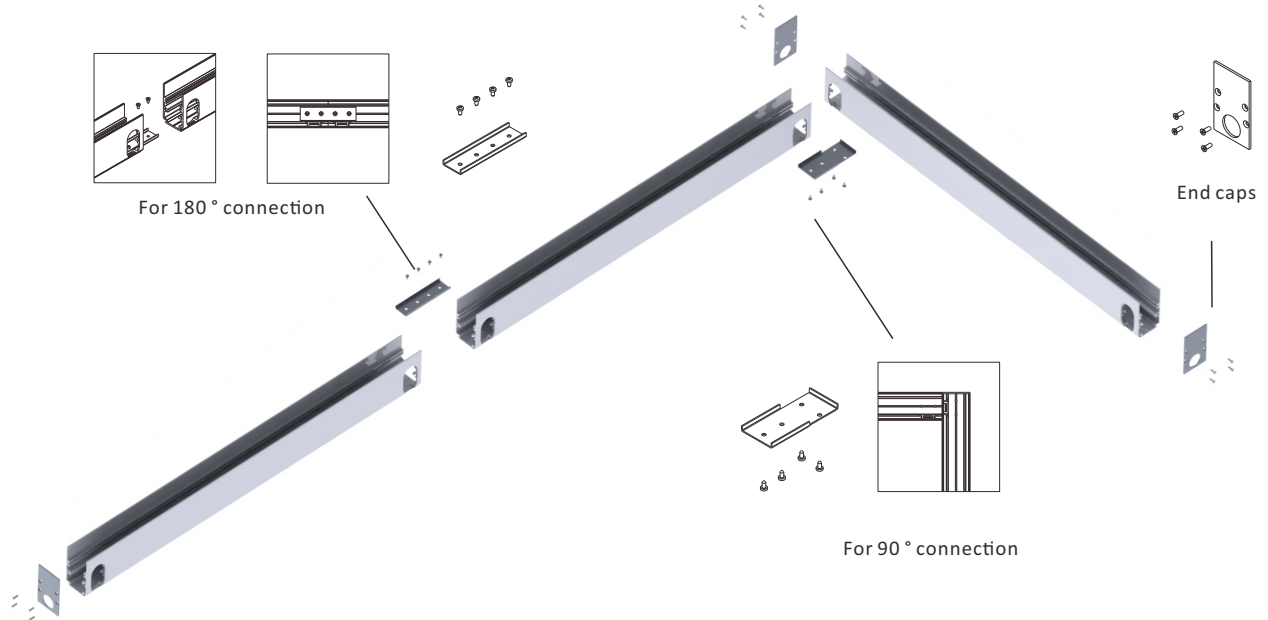

Monochrome Wiring Diagram

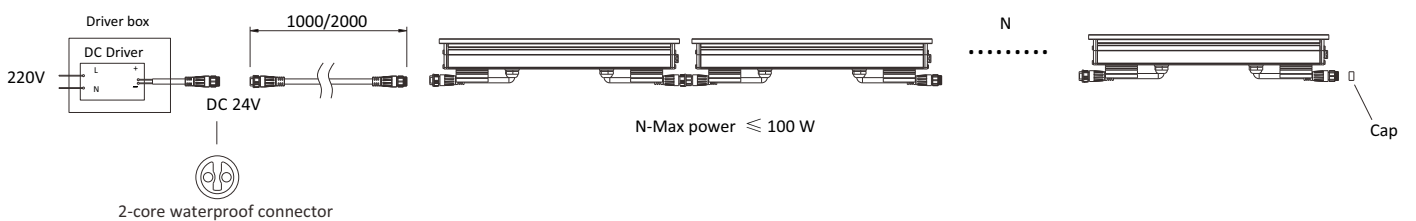

Can be used as a
STEP LIGHT & WALL LIGHT

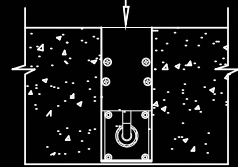
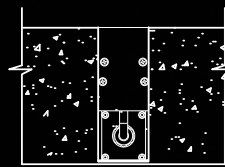
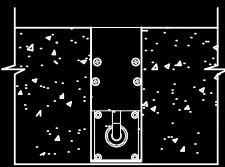
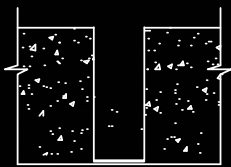
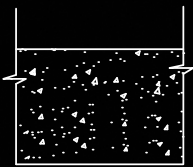
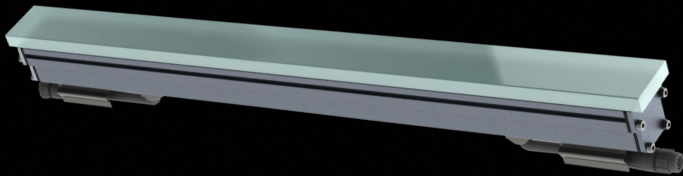
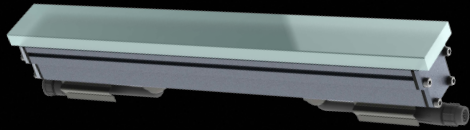



☎ 855-997-2746

📠 888-671-4872

✉ LED@SARINEnergy.com

🌐 SARINEnergy.com